

# Triple Power Lithium-ion Battery

User Manual

30Ah



## SolaX Power Network Technology (Zhejiang) Co., Ltd.

Add.: No. 288, Shizhu Road, Tonglu Economic Development Zone, Tonglu City, Zhejiang Province, 310000 P.R. CHINA  
Tel.: +86 571-56260011  
E-mail: info@solaxpower.com

Copyright © SolaX Power Technology (Zhejiang) Co., Ltd. All rights reserved.  
No part of this document may be reproduced or transmitted in any form or by any means without prior written consent of SolaX Power Technology (Zhejiang) Co., Ltd. (hereinafter referred to as SolaX). SolaX reserves the right of final interpretation.

# Contents

1	NOTE ON THIS MANUAL .....	1
1.1	SCOPE OF VALIDITY.....	1
1.2	TARGET GROUP.....	1
1.3	SYMBOLS USED.....	1
2	SAFETY .....	2
2.1	SAFETY INSTRUCTIONS .....	2
2.1.1	GENERAL SAFETY PRECAUTIONS.....	2
2.1.2	EXPLANATION OF SYMBOLS .....	3
2.2	RESPONSE TO EMERGENCY SITUATIONS .....	4
2.2.1	LEAKING BATTERIES .....	4
2.2.2	FIRE.....	4
2.2.3	WET BATTERIES AND DAMAGED BATTERIES.....	4
2.3	QUALIFIED INSTALLER.....	5
3	PRODUCT OVERVIEW .....	6
3.1	PRODUCT OVERVIEW.....	6
3.1.1	DIMENSIONS AND WEIGHT .....	6
3.1.2	INSTALLATION SPACE .....	7
3.1.3	APPEARANCE.....	8
3.2	BASIC FEATURES.....	10
3.2.1	FEATURES.....	10
3.2.2	CERTIFICATIONS.....	10
3.3	SPECIFICATIONS.....	11
3.3.1	T-BAT SYS-HV CONFIGURATION LIST .....	11
3.3.2	PERFORMANCE.....	11
4	PREPARATION BEFORE INSTALLATION .....	12
4.1	INSTALLATION PREREQUISITES.....	12
4.2	SAFETY GEAR.....	12
4.3	TOOLS .....	13
4.4	PREPARATION .....	13
4.4.1	CHECK FOR TRANSPORT DAMAGE .....	13
4.4.2	UNPACKING.....	13
4.4.3	ACCESSORIES.....	14

- 5 INSTALLATION.....16
  - 5.1 INSTALLATION OVERVIEW .....16
  - 5.2 INSTALLATION STEPS FOR BASE, BATTERY MODULES AND BMS .....19
  - 5.3 CABLE CONNECTION.....24
- 6 COMMISSIONING .....32
  - 6.1 COMMISSIONING.....32
  - 6.2 STATUS INDICATORS .....33
    - 6.2.1 BMS.....33
    - 6.2.2 BATTERY MODULE .....34
  - 6.3 SHUTTING DOWN T-BAT SYSTEM.....35
- 7 TROUBLESHOOTING .....36
  - 7.1 TROUBLESHOOTING.....36
- 8 DECOMMISSIONING.....38
  - 8.1 DISMANTLING THE BATTERY .....38
  - 8.2 PACKING.....38
- 9 MAINTENANCE.....39
- 10 DISCLAIMER .....40
- \* WARRANTY REGISTRATION FORM

# 1 Note on this Manual

## 1.1 Scope of Validity

This manual is an integral part of the T-BAT Series. It describes the assembly, installation, commissioning, maintenance and failure of the product. Read carefully prior to operation.

T-BAT BMS
MC0600
T-BAT Module
HV10230





Note: There are 4 models of the T-BAT system, which include the BMS and battery Module(s). Refer to section 3.3.1 T-BAT SYS-HV Configuration List on page 11 for detailed models.

## 1.2 Target Group

This manual is for qualified electricians. The tasks described in this manual may only be performed by qualified electricians.

## 1.3 Symbols Used

The following types of safety instructions appear in this document and are described below:

	<b>DANGER!</b> “DANGER” indicates a hazardous situation which, if not avoided, will result in serious injury or death.
	<b>WARNING!</b> “WARNING” indicates a hazardous situation which, if not avoided, could result in serious injury or death.
	<b>CAUTION!</b> “CAUTION” indicates a hazardous situation which, if not avoided, could result in minor or moderate injury.
	<b>NOTE!</b> “NOTE” provides tips that are valuable for the optimal operation of your product.

## 2 Safety

### 2.1 Safety Instructions

For safety reasons, installers are responsible for familiarizing themselves with the contents of this manual and all warnings before performing installation.

#### 2.1.1 General Safety Precautions



#### WARNING!

Do not crush or impact the battery, and always dispose of it according to safety regulations.

Observe the following precautions:

- Risks of explosion:
  - Do not subject the battery module to heavy impacts.
  - Do not crush or puncture the battery module.
  - Do not dispose of the battery module in a fire.
- Risks of fire:
  - Do not expose the battery module to temperatures in excess of 140°F.
  - Do not place the battery module near a heat source, such as a fireplace.
  - Do not expose the battery module to direct sunlight.
  - Do not allow the battery connectors to touch conductive objects such as wires.
- Risks of electric shock:
  - Do not disassemble the battery module.
  - Do not touch the battery module with wet hands.
  - Do not expose the battery module to moisture or liquids.
  - Keep the battery module away from children and animals.
- Risks of damage to the battery module:
  - Do not expose the battery module to liquids.
  - Do not subject the battery module to high pressures.
  - Do not place any objects on top of the battery module.

T-BAT SYS-HV should only be installed for residential applications and not be for commercial applications.



#### CAUTION!

If the battery is not installed within one month after receipt, it must be charged for maintenance. Non-operational batteries should be discarded according to local regulations.

#### 2.1.2 Explanation of Symbols

Symbol	Explanation
	CE mark of conformity
	TUV certification
	UKNI mark of conformity
	UKCA mark of conformity
	The battery system must be disposed of at a proper facility for environmentally-safe recycling.
	Do not dispose of the battery together with household waste.
	Wear protective glasses.
	Read the enclosed documentation.
	Keep the battery system away from open flames or ignition sources.
	Keep the battery system away from children.
	Caution, risk of electric shock
	Caution, risk of danger
	The battery module may explode.

## 2.2 Response to Emergency Situations

### 2.2.1 Leaking Batteries

In case the leakage of electrolyte solution occurs, please avoid direct contact with the electrolyte solution and the gas that may be generated by it. Direct contact may lead to skin irritation or chemical burns. If the user comes into contact with the electrolyte solution, please do as follows:

Accidental inhalation of harmful substances: Evacuate from the contaminated area, and seek medical attention immediately.

Eye contact: Rinse eyes with flowing water for 15 minutes, and seek medical attention immediately.

Dermal contact: Wash the affected area thoroughly with soap and water, and seek medical attention immediately.

Ingestion: Induce vomiting, and seek medical attention immediately.

### 2.2.2 Fire

Please keep a Class ABC fire extinguisher or a carbon dioxide extinguisher near the equipment.



**WARNING!**  
The battery module may catch fire when heated above 302°F.

If a fire breaks out where the battery module is installed, please do as follows:

- 1) Extinguish the fire before the battery module catches fire;
- 2) If the battery module catches fire, please do not try to put out the fire, and evacuate immediately.



**WARNING!**  
In case of catching fire, the battery module will produce noxious and poisonous gases, and please keep away the battery.

### 2.2.3 Wet Batteries and Damaged Batteries

Do not touch the battery module after being wet from and soaked in the water.

Do not use the battery module if it is damaged. Otherwise, the loss to life and property will be caused.

Please pack the battery in its original packaging, and return it to the company or the distributor.



**CAUTION!**  
Damaged batteries may leak electrolyte or produce flammable gas. If a user suspects that the battery is damaged, please immediately contact the company for advice and information.

## 2.3 Qualified Installer



### WARNING!

All operations of T-BAT SYS-HV relating to electrical connection and installation must be carried out by qualified personnel.

A skilled worker is defined as a trained and qualified electrician or installer who has all of the following skills and experience:

- Knowledge of the functional principles and operation of grid-tied systems
- Knowledge of the dangers and risks associated with installing and using electrical devices and acceptable mitigation methods
- Knowledge of the installation of electrical devices
- Knowledge of and adherence to this manual and all safety precautions and best practices

### 3 Product Introduction

#### 3.1 Product Overview

For safety reasons, installers are responsible for familiarizing themselves with the contents of this manual and all warnings before performing installation.

##### 3.1.1 Dimensions and Weight

A battery management system (BMS) is an electronic system that manages a rechargeable battery.

A battery module is a type of electrical battery which can be charged or discharged into a load.

A battery system includes the BMS and battery module(s).

	Base	MC0600	HV10230
Length	482 mm	482.5 mm	482.5 mm
Height	60 mm	173.5 mm	471.5 mm
Width	167 mm	153 mm	153 mm
Weight	2.5 KG	7.5 KG	34.5 KG

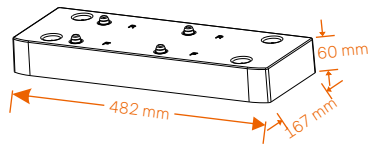

Base Mounting

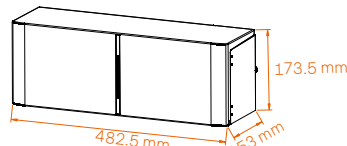

BMS  
(MC0600)

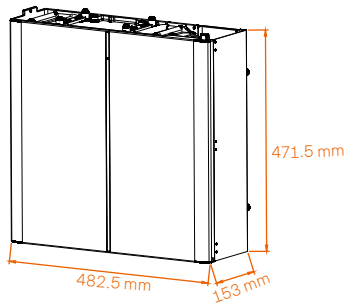

Battery Module  
(HV10230)

#### 3.1.2 Installation Space

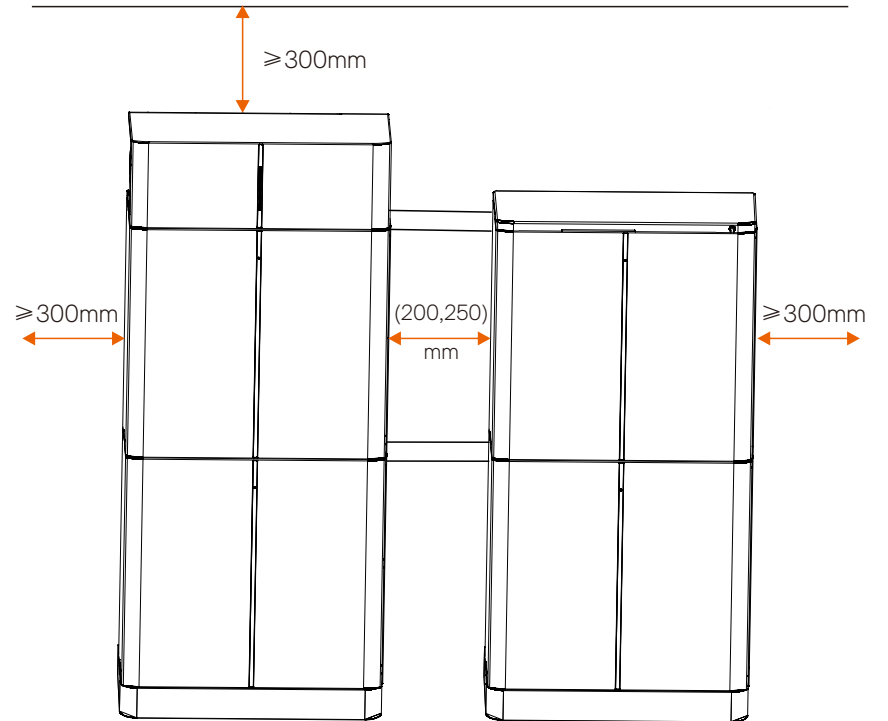

3.1.3 Appearance

- Section view of MC0600

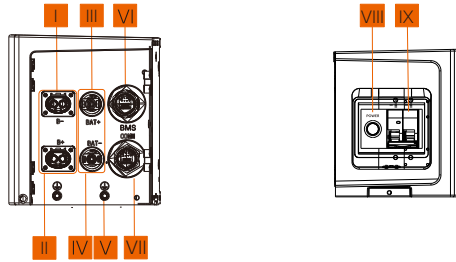

Object	Mark	Description
I	B-	Connector B- of BMS to B- of battery module
II	B+	Connector B+ of BMS to B+ of battery module
III	BAT+	Connector BAT+ of BMS to BAT+ of inverter
IV	BAT-	Connector BAT- of BMS to BAT- of inverter
V	⊕	GND
VI	BMS	Connector BMS of BMS to BMS of inverter
VII	COMM	Connector COMM of BMS to COM1 of battery module
VIII	POWER	Power Button
IX	ON/OFF	Circuit Breaker

- Section view of HV10230

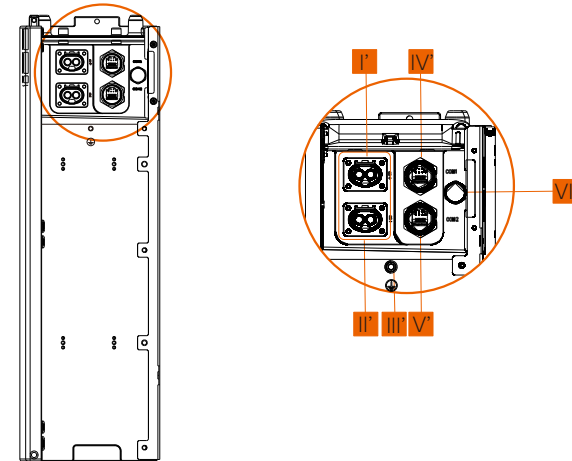

Object	Mark	Description
I'	B+	Connector B+ of BMS, or B- of upper/next battery module
II'	B-	Connector B- of BMS, or B+ of upper/next battery module
III'	⊕	GND
IV'	COM1	Connector to BMS COMM, or COM2 of next battery module
V'	COM2	Connector to COM1 of next battery module
VI'	/	Air Valve

## 3.2 Basic Features

### 3.2.1 Features

The T-BAT SYS-HV is one of the most advanced energy storage systems on the market today, incorporating state-of-the-art technology, high reliability, and convenient control features shown as below:

- 90% DOD
- 95% Battery Roundtrip Efficiency
- Cycle Life > 6000 Cycles
- Secondary Protection by Hardware
- Ip65 Protection Level
- Safety & Reliability
- Small Occupied Area
- Floor or Wall Mounting

### 3.2.2 Certifications

BAT system safety	CE, RCM, IEC 62619
UN number	UN 3480
Hazardous materials classification	Class 9
UN transportation testing requirements	UN 38.3
International protection marking	IP 65

## 3.3 Specifications

### 3.3.1 T-BAT SYS-HV Configuration List

No.	Model	BMS	Battery Module	Energy (kWh)	Voltage (V)
1	T-BAT H 3.0	MC0600 × 1	HV10230 × 1	3.1	90-116
2	T-BAT H 6.0	MC0600 × 1	HV10230 × 2	6.1	180-232
3	T-BAT H 9.0	MC0600 × 1	HV10230 × 3	9.2	270-348
4	T-BAT H 12.0	MC0600 × 1	HV10230 × 4	12.3	360-464

### 3.3.2 Performance

Model	T-BAT H 3.0	T-BAT H 6.0	T-BAT H 9.0	T-BAT H 12.0
Nominal Voltage (Vdc)	102.4	204.8	307.2	409.6
Operating Voltage (Vdc)	90-116	180-232	270-348	360-464
Nominal Capacity (Ah) <sup>①</sup>	30	30	30	30
Nominal Energy (kWh) <sup>①</sup>	3.1	6.1	9.2	12.3
Usable Energy (kWh) <sup>②</sup>	2.8	5.5	8.3	11.0
Max. Charge/Discharge Current (A) <sup>③</sup>	30	30	30	30
Recommend Charge/Discharge Current (A)	25	25	25	25
Standard Power (kW)	2.55	5.1	7.65	10.2
Max. Power (kW)	3.1	6.1	9.2	12.3
Battery Roundtrip Efficiency (0.2C, 25°C/77°F)	95%			
Expected Lifetime (25°C/77°F)	10 years			
Cycle Life90% DOD (25°C/77°F)	6000 cycles			
Available Charge/Discharge Temperature Range	-30°C~55°C (with heating function) <sup>④</sup>			
	-10°C~55°C (no heating function) <sup>⑤</sup>			
Storage Temperature	-20°C~50°C (3 months)			
	0°C~40°C (12 months)			
Ingress Protection	IP65			

① Test conditions: 100% DOD, 0.2C charge & discharge @+25°C.

② 90% DOD; System usable energy may vary with inverter different setting.

③ Discharge: In case of the battery core's temperature range of -10~10°C and 45~55°C, the discharge current will be reduced; Charge: In case of the battery core's temperature range of 1~25°C and 45~55 °C, the charge current will be reduced. Product charge or discharge power depends on the actual temperature of the battery pack.

④ The battery can be discharged and charged at -30~0°C.

⑤ The battery can be discharged but not be charged in the temperature interval -10~0°C.



## 4 Preparation before Installation

### 4.1 Installation Prerequisites

When assembling the system, avoid touching the battery terminals with any metal object or bare hands. According to the design principles, T-BAT-SYS-HV will provide a safe and reliable energy. Improper operation and equipment damage may cause overheating and electrolyte leakage. Therefore, the above-mentioned safety precautions and warning information mentioned in this part shall be strictly observed. If you have any question, please contact customer service. The “2 Safety” does not contain the provisions of all laws and regulations at the place where the user located.

Before installation, make sure that the installation site meets the following conditions:

- The building can stand up to earthquakes;
- The site shall be over 0.62 miles away from the sea, to avoid damage caused by salt water and humidity;
- The floor shall be flat;
- No inflammable and explosive goods are placed within at least of 3 ft;
- The ambience shall be shady and cool, away from heat sources and direct sunlight;
- The temperature and humidity remain at a constant level;
- The installation site requires less dust and dirt;
- There are no corrosive gases, including ammonia and acid vapor; and
- The same generation products are recommended to give priority to use.

In practice, the requirements of battery installation may be different due to environment and locations.

In that case, follow up the exact requirements of the local laws and standards.

#### NOTE!



If the ambient temperature exceeds the operating range, the battery Pack will stop operating to protect itself. The optimal temperature range for operation is 59°F to 86°F. Frequent exposure to harsh temperatures may deteriorate the performance and lifetime of the battery module.

### 4.2 Safety Gear

Installation and maintenance personnel must operate according to applicable federal, state, and local regulations as well as industry standards regarding product installation. Personnel must wear safety gear as indicated below in order to avoid short circuit and personal injury.



Insulated Gloves



Safety Goggles



Safety Shoes

### 4.3 Tools

These tools are required to install the T-BAT system.



Torque Screw Driver



Phillips-Screw Driver

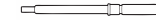

Hexagon Wrench



Phillips-Head Screw Driver



Flat-Head Screw Driver



Torque Wrench

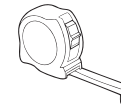

Tape Measure



Drill



Pencil or Marker

### 4.4 Installation

#### 4.4.1 Check for Transport Damage

Ensure the battery is intact during and after transportation. If there are visible Damages such as cracks, contact your dealer immediately.

#### 4.4.2 Unpacking

Unpack the battery package by removing the packing tape. Ensure the battery modules and relevant items are complete. Refer to the packaging items in section 4.4.3 and check the packing lists carefully. If any items are missing, immediately contact the company or your distributor directly.



#### CAUTION!

According to the regional regulations, several people may be required for moving the equipment.



#### WARNING!

Please strictly follow the installation steps. The company shall not bear any responsibility for any injury and loss caused by improper installation and operation.



#### NOTE!

For the first installation, the interval among manufacture dates of battery modules shall not exceed 3 months.

4.4.3 Accessories

BMS (MC0600):

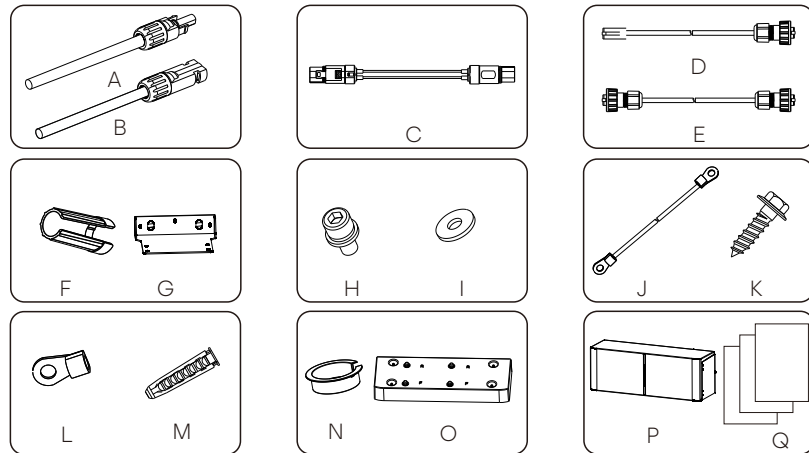

The table below lists the number of each component.

Object	Description	Quantity
A	Charging Cable (+) (2000 mm)	1
B	Charging Cable (-) (2000 mm)	1
C	Power Cable between BMS and Battery Module (120 mm)	1
D	BMS Communication Cable (2000 m)	1
E	COMM Communication Cable (200 mm)	1
F	Rotation Wrench	1
G	Wall Bracket	1
H	M5 Combination Screw	4
I	Flat Gasket	2
J	Earth Wire (150 mm)	1
K	Expansion Screw	2
L	Ring Terminal (for grounding)	2
M	Expansion Bolt	2
N	Guard Ring	2
O	Base	1
P	BMS	1
Q	Documentation	1

One Battery Module (HV10230 × 1):

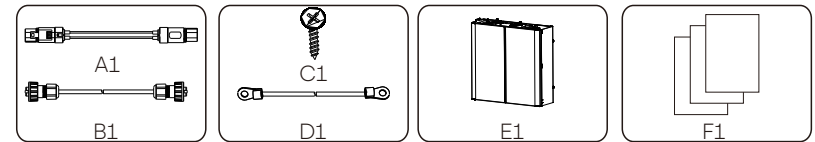

Accessories (1) of three and four Battery Modules (HV10230 × 3/4):

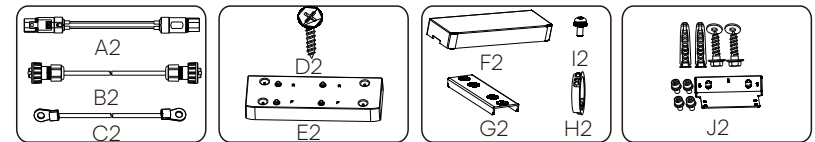

Accessories (2) of three and four Battery Modules (HV10230 × 3/4):

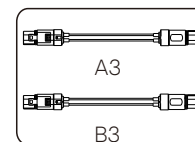

Note: A3 × 1 and B3 × 1 need to be purchased separately

The table below lists the number of each component.

Object	Description	Quantity
A1	Power Cable between BMS and Battery Module (690 mm)	1
B1	COMM Communication Cable (600 mm)	1
C1	ST3.9*16 Screw	2
D1	Ground Wire (450 mm)	1
E1	Battery Module	1
F1	Documentation	1
A2	Power Cable between Battery Modules (1200 mm)	1
B2	COMM Communication Cable of Battery Module (1200 mm)	1
C2	Ground Wire (1200 mm)	1
D2	ST3.9*16Screw	2
E2	Base Mounting	1
F2	Cover	1
G2	Supporting Bracket	2
H2	Guard Ring	4
I2	M4 Screw	8
J2	Accessories of Wall Bracket	1
A3	Power Cable between Battery Modules or BMS (1200 mm)	1
B3	Power Cable between BMS and Battery Module (1800 mm)	1

## 5. Installation

### 5.1 Installation Overview

According to the battery used, choose the following corresponding form for installation.

(1): MC0600 × 1 + HV10230 × 1

(2): MC0600 × 1 + HV10230 × 2

(3): MC0600 × 1 + HV10230 × 3

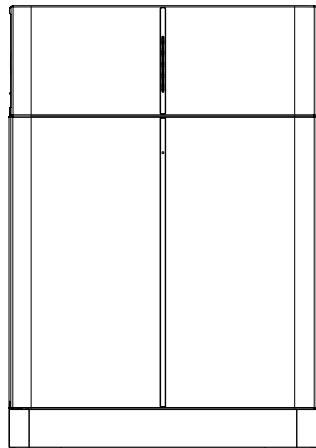

BMS + Bat x 1  
Installation distance:  
Left:  $\geq 300$  mm  
Right:  $\geq 300$  mm

(a)

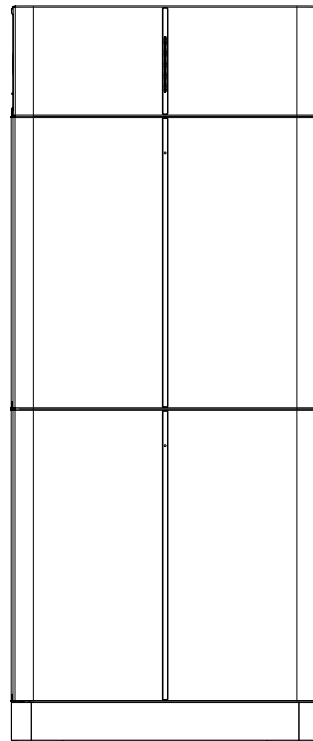

BMS + Bat x 2  
Installation distance:  
Left:  $\geq 300$  mm  
Right:  $\geq 300$  mm

(b)

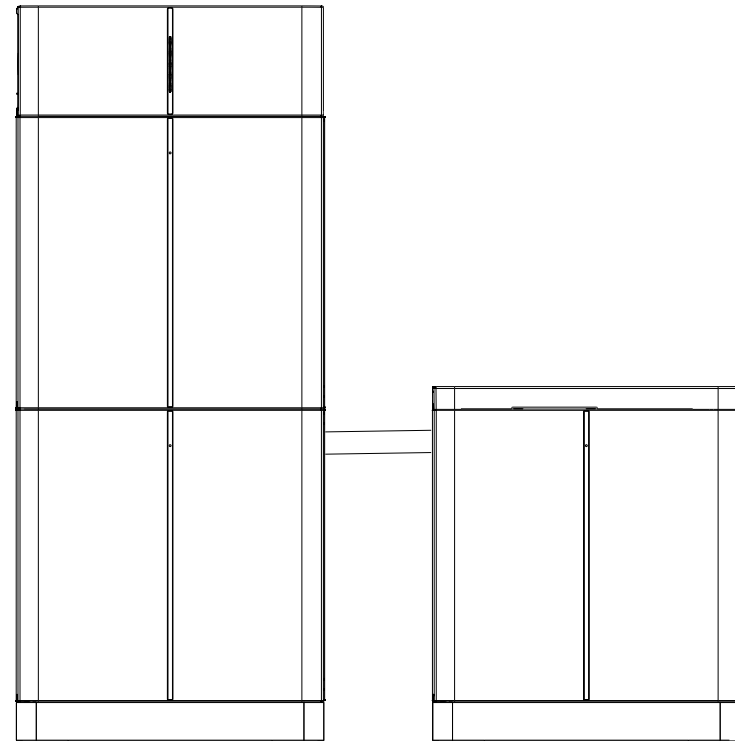

BMS + Bat x 3  
Installation distance:  
Left:  $\geq 300$  mm  
Right:  $\geq 300$  mm  
Distance between battery columns: 200 mm ~250 mm

(c)

A corrugated pipe is recommended to use to protect the outside cables between the battery columns.

(4): MC0600 × 1 + HV10230 × 4

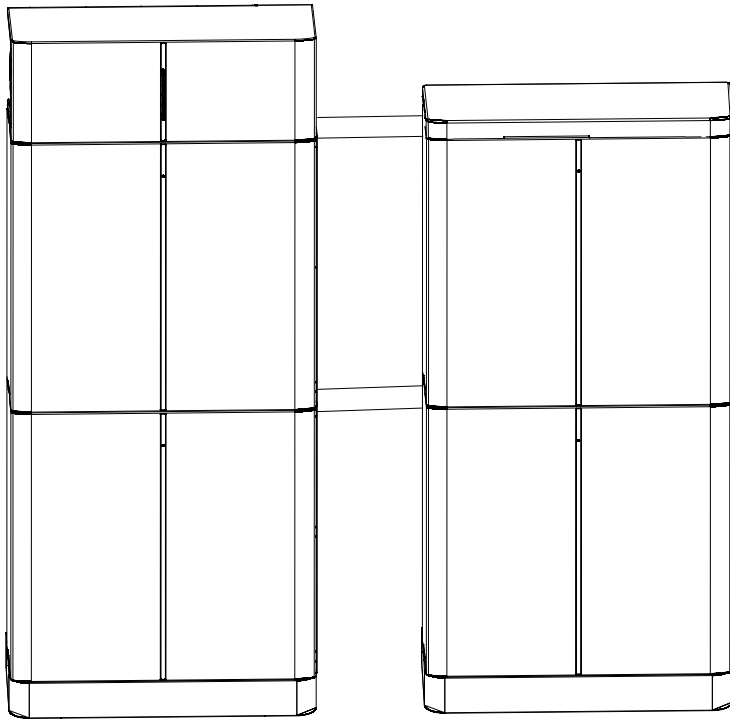

BMS + Bat x 4  
 Installation distance:  
 Left: ≥300 mm  
 Right: ≥300 mm  
 Distance between battery columns: 200 mm ~250 mm

(d)



**DANGER!**

One T-BAT system can contain at most **four** battery modules. Connecting more than four battery modules will blow the fuse and the battery module(s) will be damaged. Ensure the number of battery module(s) meets this requirement.

## 5.2 Installation Steps for Base, Battery Modules and BMS

Before installation, please make sure the wall is strong enough to withstand the weight of Battery.

There are 4 installation modes alternative for users. Take the installation procedures for “a” (on the page 16) and “c” on the page 17) as an example, with details as follows:

(1): MC0600 × 1 + HV10230 × 1 (“a” on the page 16)

Step 1: The Single Battery Base shall be located 193±2 mm away from the wall, and adjust the Base with a torque wrench to ensure that it is parallel to the ground. A spirit level is required.

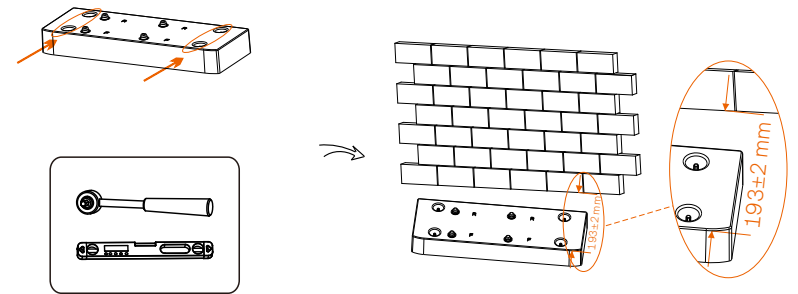

Note:

The letter “R” and “F” on the Base respectively indicate Rear and Front. Therefore, the side with “R” shall be against the wall.

Step 2: Place a battery module on the top of the Base.

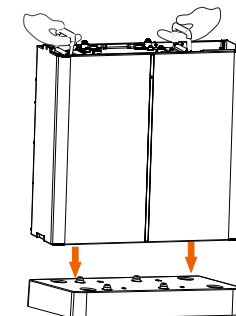

Step 3: Place the Wall Bracket, determine the position of holes, mark it with a pen, remove the Wall Bracket, and then drill the two holes ( 10 mm).

Step 4: Place Expansion Bolts into the holes.

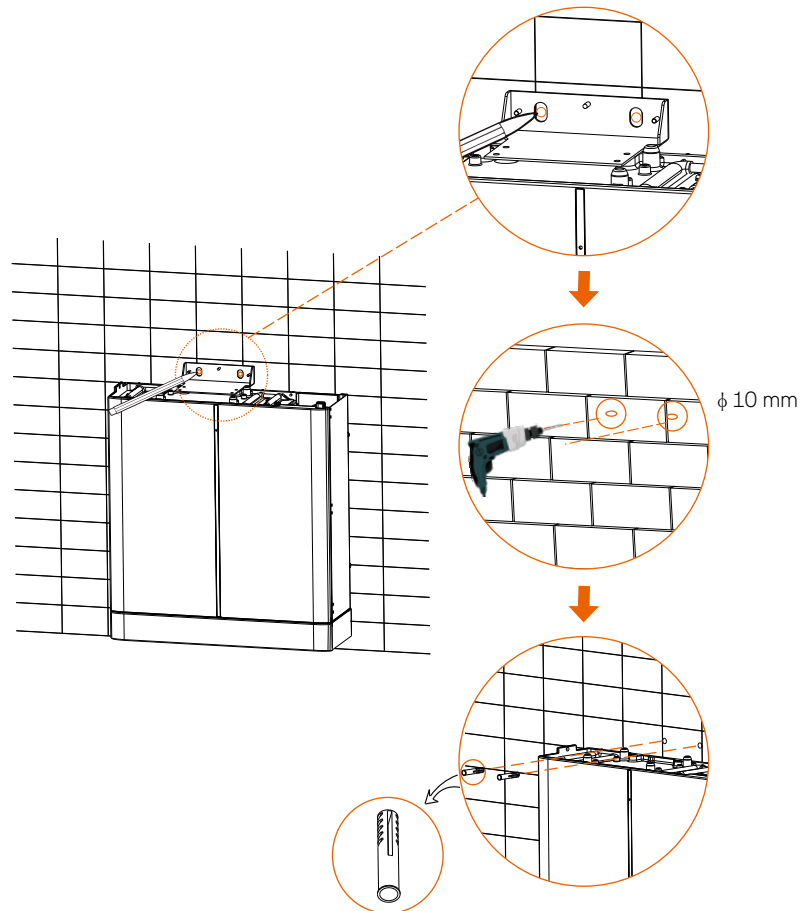

**Note!**

The Wall Bracket(s) must be installed to secure the battery module(s) connecting the cover or/and BMS.

Step 5: Secure the Wall Bracket to the battery using screws (2 X M5\*10, torque: 2.2-2.5 N·m) and to the wall using Tapping Screws (2 X ST6\*L55) and Flat Gaskets (2).

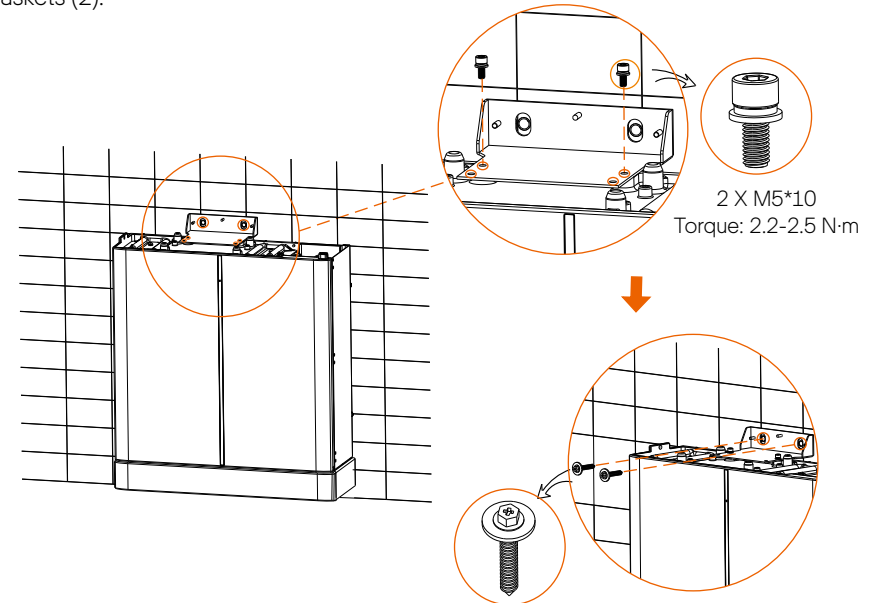

Step 6: Place BMS on the top of the battery module, and secure both left and right sides with M4 screws (2). See figure below.

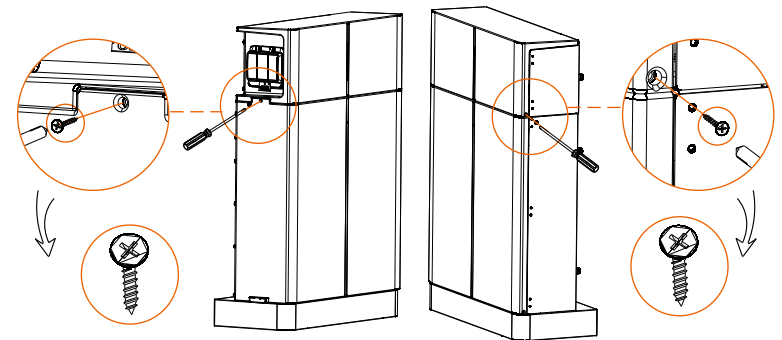

**Note!**

Don't forget to screw both left and right sides of battery modules installed. The above steps also apply to place 2 battery modules ("b" on the page 16).

(2) MC0600 × 1 + HV10230 × 3 (“c” on the page 17)

As for the installation of “Left: BMS + 2 x BAT, Right: 1 x BAT”, please refer to the Step 1 to 6 of “(1) MC0600 × 1 + HV10230 × 1” on the page 19 to 21 .

After finishing the installation of two bases and three batteries, for the installation of cover, please follow the steps below.

Step 1: Secure supporting brackets using screws (4 X M4\*10, torque: 0.8-1.2 N·m).

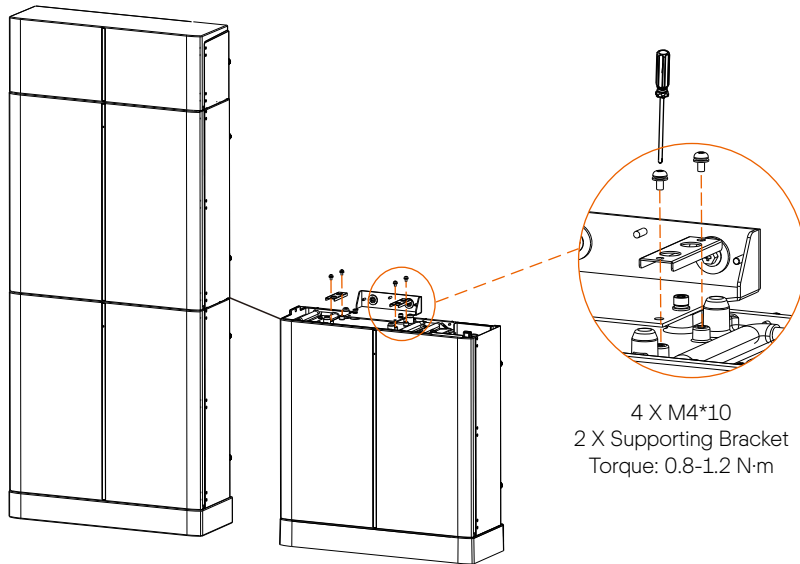

Step 2: Put the cover on the battery module. See figure below.

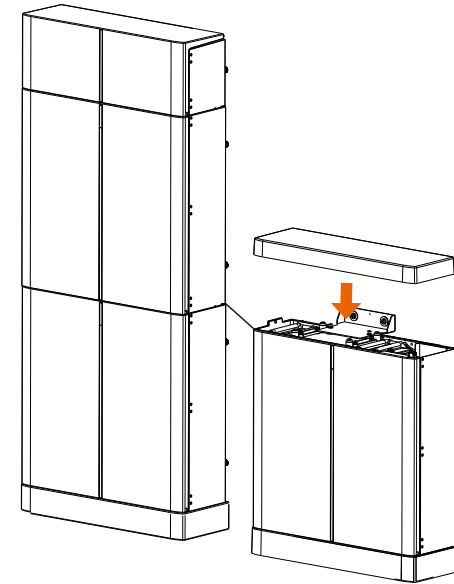

 Note!

The above steps also apply to place 4 battery modules (“d” on the page 18).

### 5.3 Cable Connection

Before connecting the inverter, please check the cable length by hand

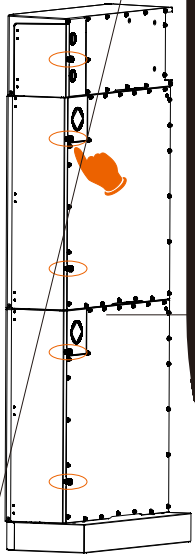

Installation procedures for connecting inverter

Inverter:  
 + (A: 2000 mm),  
 - (B: 2000 mm),  
 (D: 2000 mm)

Connection Steps:

The cable for connecting to inverter from BMS is delivered with the inverter, for more details please refer to the inverter's User Manual.

Connecting the BMS Communication Cable

The BMS communication cable is used for the BMS to communicate with the inverter for proper operation.  
 Note that the BMS communication cable is shielded with steel tubes.  
 The wire order of the communication cable is the same as the BMS communication cable.

Sequence	1	2	3	4	5	6	7	8
BMS	/	GND	/	BMS_H	BMS_L	/	A1	B1

Notes for Unplugging Power Cables



**CAUTION!**  
Do not plug or unplug the power cables when the T-BAT system is on. Doing so could result in an arc discharge which could cause serious harm.

1) Shut down the T-BAT system (refer to Section 6.3 Shutting Down T-BAT System of User Manual on page 30)

- 2) Remove the lock cover
- a. Pull the back end of the lock cover using a finger or an instrument.
  - b. Remove the lock cover and store for later use

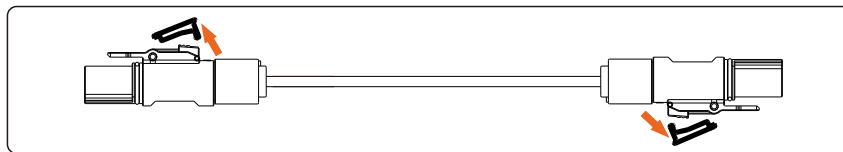
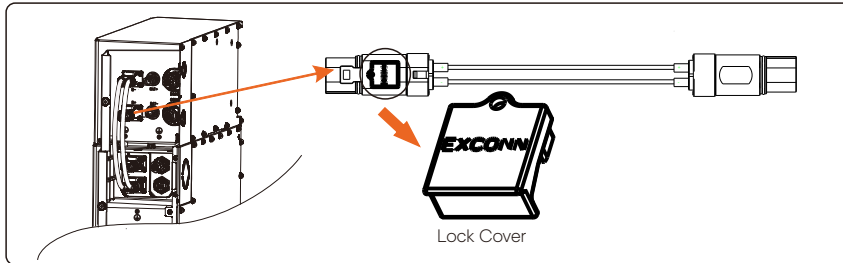

3) Push the plastic button on each end of the power cable in the direction of the arrow

4) Unplug the power cable

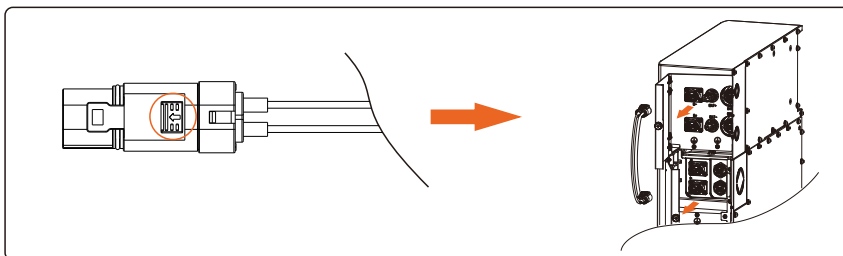

2 Connecting the COMM Communication Cable

- 1) Connect the COMM communication cable (E) from the right side of the BMS to the COM1 communication port that is on the right side of the battery module.
- 2) Connect the COM1 of the upper battery module on the right side to COM1 of the follow-up battery module.
- 3) Tighten the plastic screw nut which is set on the cable with a rotation wrench.

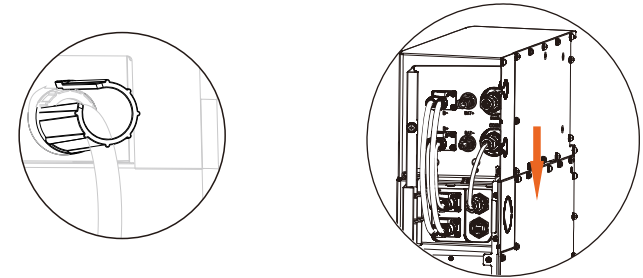

The wire order of the communication cable is as follows:

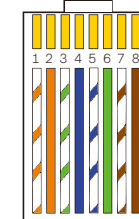
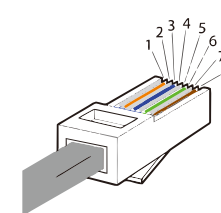

- 1) Orange stripes on white
- 2) Orange
- 3) Green stripes on white
- 4) Blue
- 5) Blue stripes on white
- 6) Green
- 7) Brown stripes on white
- 8) Brown

Sequence	1	2	3	4	5	6	7	8
COM1	VCC_1	GND	VCC_2	CANH	CANL	GND	N-	P+
COM2	VCC_1	GND	VCC_2	CANH	CANL	GND	N-	P+

3 Connecting the Ground Wire

For BMS and 3-4 battery modules:

Connect the ground wire from the BMS to the battery module

Note: 10 AWG ground wire is required for grounding

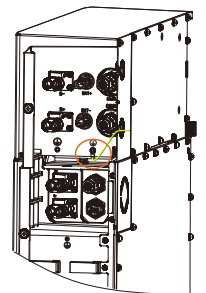



4 Connecting Cables to Battery Modules

**Note!**

Regardless of how many battery modules installed, please put a waterproof cap on the communication port of the unconnected port of battery module (see the circle in the following figures).

➤ For one battery module:

Ensure that both ends of the cables are connected to the correct connector, which are on the right side of the BMS and battery module.

BMS and battery module are required to connect ground wire (F: 150 mm).

BMS to Battery1:

B+ to B+ (C: 1200 mm)

B- to B- (A1: 690 mm)

COMM to COM1 (E: 200 mm)

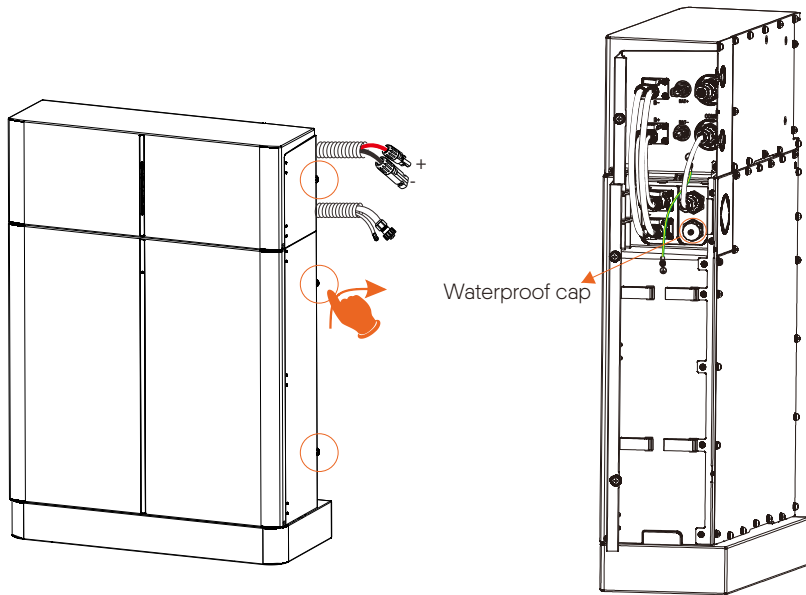

➤ For two battery modules:

Ground wires are required to be connected. (C1 (450 mm) is used for connecting two battery modules.)

BMS to Battery1: B+ to B+ (C: 1200 mm); COMM to COM1 (E: 200 mm)

Battery1 to Battery2: B- to B+ (A1: 690 mm); COM2 to COM1 (B1: 600 mm)

Battery2 to BMS: B- to B- (A1: 690 mm)

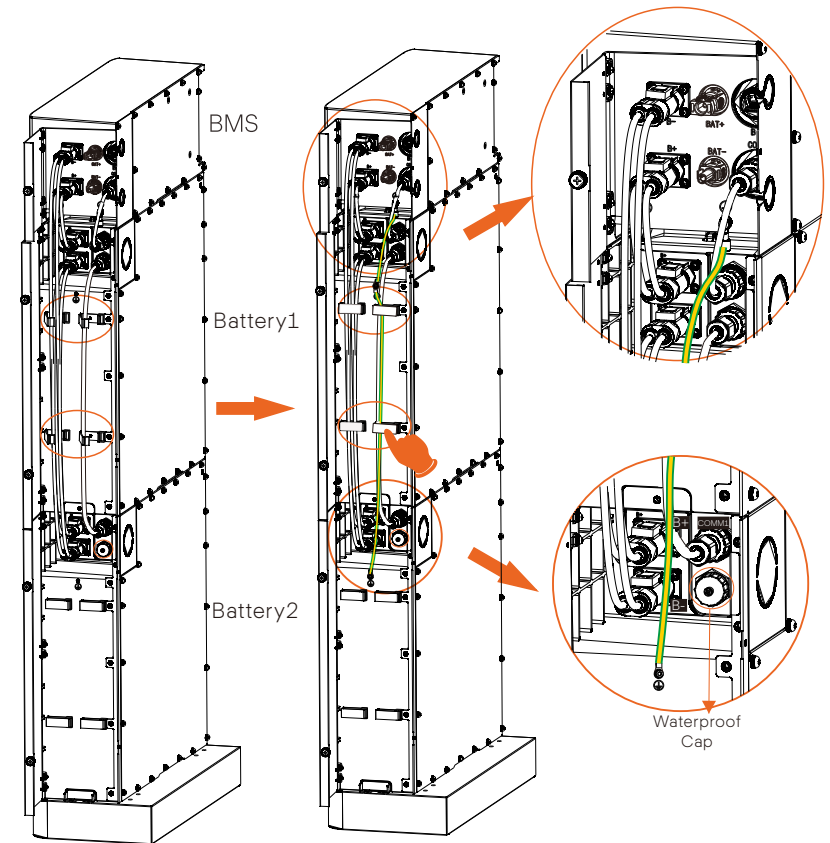

► For three battery modules:

Ground wires are required to be connected. (C2: 1200 mm is used for connecting battery modules.)

BMS to Battery1:  
B+ to B+ (C: 120 mm); COMM to COM1 (E: 200 mm);

BMS to Battery3:  
B- to B- (B3: 1.8 m); Get the cables through corrugate pipe.

Battery1 to Battery2:  
B- to B+ (A1: 690 mm); COM2 to COM1 (B1: 600 mm)

Battery2 to Battery3:  
B- to B+ (A2: 1.2 m); COM2 to COM1 (B2: 1.2 m); Get the cables through corrugate pipe.

BMS to Battery1:  
B+ to B+ (C: 120 mm); COMM to COM1 (E:200 mm);  
Battery1 to Battery2:  
B- to B+ (A1: 690 mm); COM2 to COM1 (B1: 600 mm);  
Battery2 to Battery3:  
B- to B+ (A2: 1.2 m); COM2 to COM1 (B2: 1.2 m);  
Battery3 to Battery4:  
B- to B+ (A1: 690 mm) and COM2 to COM1 (B2: 1.2 m), get the cables through corrugate pipe;  
Battery4 to BMS:  
B- to B- (A3: 1.2 m), get the cable through corrugate pipe.

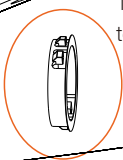
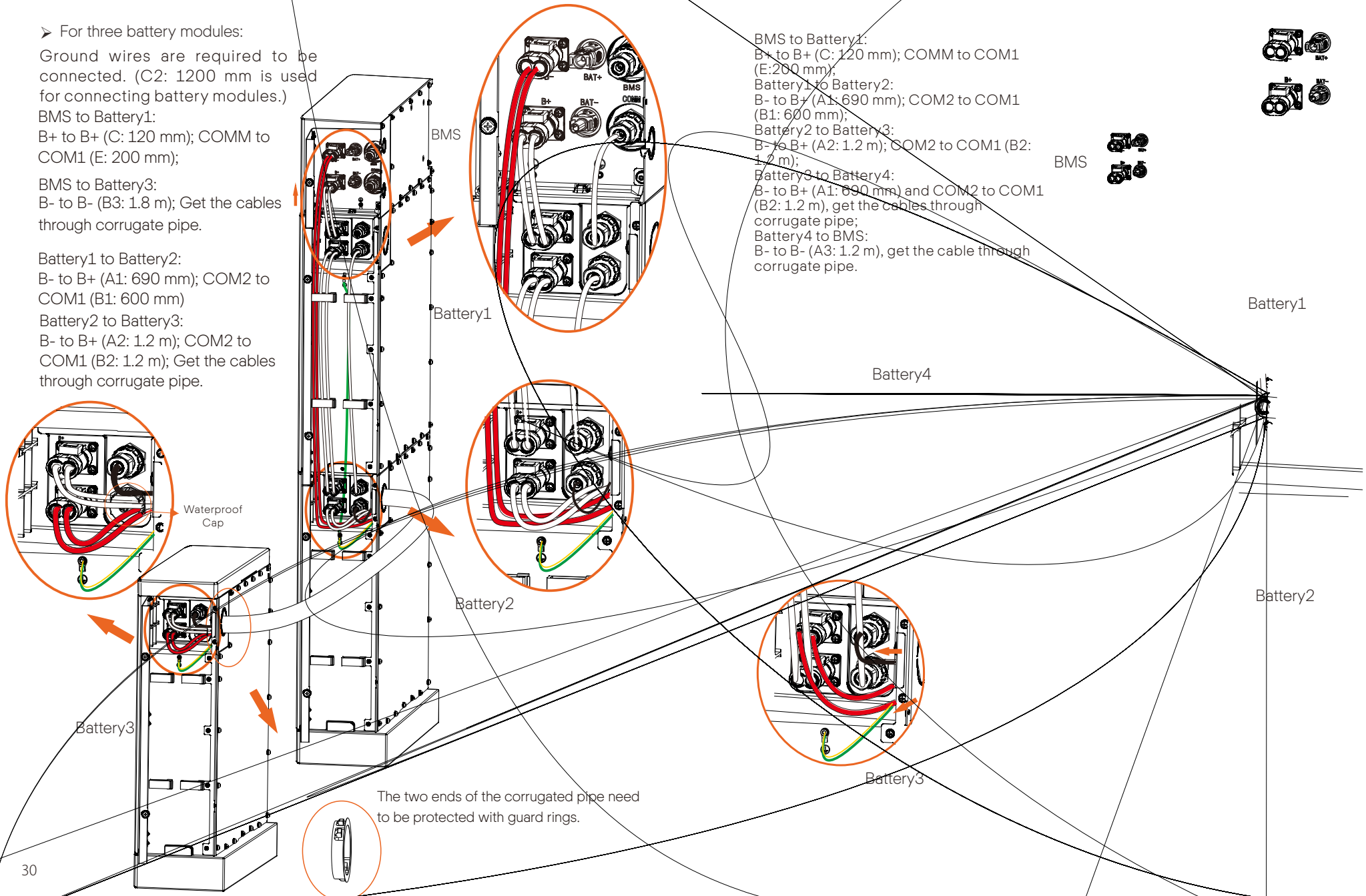
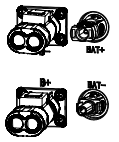

The two ends of the corrugated pipe need to be protected with guard rings.

## 6 Commissioning

### 6.1 COMMISSIONING

Verify the model number of each battery module to ensure that they are all the same model.

Once all battery modules are installed, follow these steps to start the system:

- 1) Open the cover of the BMS;
- 2) Move the circuit breaker switch to "ON";
- 3) Press and hold the POWER button for more than 1s to start the T-BAT system;
- 4) Turn on the AC switch of inverter

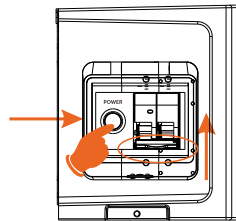

#### NOTE!



Frequently pressing the POWER button may cause a system error. Wait at least 10 seconds after pressing the POWER button prior to making another attempt.

Our equipment can provide Black Start capability, meaning that our energy storage inverter and battery can continue to run even if the power grid and photovoltaic panel are out of service. The startup procedure for Black Start is set forth: Press the POWER button and hold it for 20 sec; release the button after the four SOC indicators (1<sup>st</sup> and 4<sup>th</sup> indicators, 2<sup>nd</sup> and 3<sup>rd</sup> indicators) flash blue alternately; at this point, it will show its current battery charge and enter the Black Start status.

#### Note!



We do not recommend the use of Black Start as it may cause the communication port to be charged, resulting in an electric shock.

## 6.2 Status Indicators

### 6.2.1 BMS (MC0600)

The LED indicators on the front panel of the battery pack are showing the operating status.

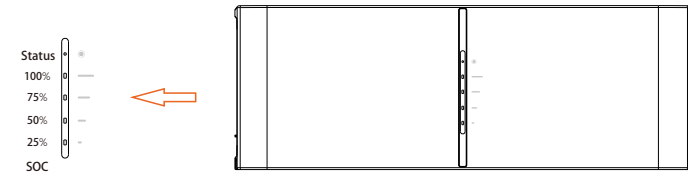

The following table shows the status of BMS.

No.	Status of BMS	Mode
1	Light off	Power off
2	The Green LED is light on for 1s, and light off for 4s	Inverter sends Idle command
3	The Orange LED is light on for 1s, and light off for 4s	BMS Protection
4	The Red LED keeps lighting on for 10min, then Flickers with light on for 1s, and light off for 4s	Fault
5	The Green LED is light on for 0.3s, and light off for 0.3s	Upgrade for BMS
6	The Green LED keeps light on	Active
7	Press the POWER button and hold it for 20 sec; release the button after the four SOC indicators (1 <sup>st</sup> and 4 <sup>th</sup> indicators, 2 <sup>nd</sup> and 3 <sup>rd</sup> indicators) flash blue alternately, and then enter the Black Start status.	Black Start

The capacity indicators show the SOC:

- When the battery pack is neither charging nor discharging, the indicator lights are off.
- When the battery pack is charging, part of the Blue LED flashes with the frequency of light on for 0.5s, light off for 0.5s, and part of the Blue LED keeps light on. Take SOC 60% for instance, in charging state:
  - 1). The first two Blue LED indicators keep on
  - 2). The third Blue LED indicator flashes once every 1s
- When the battery pack is discharging, the Blue LED flashes with the frequency of light on for 1s, and light off for 4s. Take SOC 60% for instance, in discharging state:
  - 1). The first three blue LED indicators flash once every 5 seconds

## 6.2.2 Battery Module (HV10230)

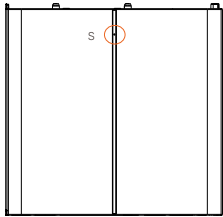

S represents independent status indicators. The status of S has the same meaning for battery modules in the following table.

Note: The battery system is active only when both S are flashing in Green LED every 5 seconds.

No.	Status of battery module	Mode
1	Green LED flashes once every 5 sec	Active
2	Yellow LED flashes once every 5 sec	Protection
3	Red LED flashes once every 5 sec	Fault
4	Red, Green and Yellow LED flash alternately	Upgrade for theBMS

## 6.3 Shutting Down T-BAT System

To shut down the system, follow the steps described below:

- 1) Turn off the breaker between the inverter and T-BAT System
- 2) Long press 10s to shut down the BMS
- 3) Turn off the system by moving the circuit breaker switch to the OFF position
- 4) Ensure that every indicator on the T-BAT system is off
- 5) Disconnect the cables

**NOTE!**

After powering off the BMS, the LED lights for S will keep flashing for 20 minutes.

## 7 Troubleshooting

### 7.1 Troubleshooting

Check the previous indicators to determine the status of the T-BAT system. A warning state is triggered when conditions such as voltage or temperature exceed the design limitations. T-BAT system's BMS periodically reports its operating state to the inverter.

When the T-BAT system falls outside the prescribed limits, it enters into a warning state.

When a warning is reported, the inverter immediately stops its operation.

Use the monitoring software on the inverter to identify what caused the warning.

The possible error messages are as follows:

Error Messages	Description	Troubleshooting
BMS_Ver_Unmatch	The version of BMS is unmatched	Contact your distributor or the company directly for servicing.
BMS_Internal_Err	1) DIP switch on the wrong position 2) The communication between battery modules is interrupted. 3) There's probably a water leakage to communication port.	1) Move the DIP switch to the correct position. 2) Check if the communication cable between the battery modules is correctly and properly connected. 3) Put a waterproof cap on the communication port of the upper battery module.
BMS_OverVoltage	Battery over voltage	Contact your distributor or the company directly for servicing.
BMS_LowerVoltage	Battery under voltage	Contact your distributor or the company directly for servicing.
BMS_ChargeOCP	Battery charge over current protection	Contact your distributor or the company directly for servicing.

Warning Messages	Description	Troubleshooting
BMS_TemHigh	Battery over temperature	Wait until the temperature of the cells returns to the normal state.
BMS_TemLow	Battery under temperature	Wait until the temperature of the cells returns to the normal state.
BMS_DischargeOCP	Battery discharge over current protection	Contact your distributor or the company directly for servicing.
BMS_Hardware_Protect	Battery hardware under protection	Contact your distributor or the company directly for servicing.
BMS_Insulation_Fault	Battery insulation fault	Contact your distributor or the company directly for servicing.
BMS_VoltSensor_Fault	Battery voltage sensor fault	Contact your distributor or the company directly for servicing.
BMS_TempSensor_Fault	Battery temperature sensor fault	Contact your distributor or the company directly for servicing.
BMS_CurrSensor_Fault	Battery current sensor fault	Contact your distributor or the company directly for servicing.
BMS_Relay_Fault	Battery relay fault	1) Ensure the power cable is correctly and properly connected to the power connector (XPLUG) of BMS; 2) If the equipment still cannot run properly after confirming that the power cable is connected correctly, contact your distributor or the company directly.
BMS_Type_Unmatch	The type of BMS is unmatched	Contact your distributor or the company directly for servicing.

## 8 Decommissioning

### 8.1 Dismantling the Battery

#### Shutting down the battery unit

- Disconnect the cables between the BMS and inverter
- Disconnect the series wiring terminal on the battery
- Disconnect the cables

### 8.2 Packing

Pack the BMS and battery modules in the original packaging.

If the original packaging is no longer available, use an equivalent carton or box that meets the following requirements:

- Suitable for loads over 154.32 lbs
- Properly closed and sealed

## 9 Maintenance

-If the ambient temperature for storage is  $-4$ - $113^{\circ}\text{F}$ , recharge the batteries at least one time every 3 months.

-If the ambient temperature for storage is  $-4$ - $68^{\circ}\text{F}$ , recharge the batteries at least once every 6 months.

-If the batteries have not been used for more than 9 months, these batteries must be charged to at least SOC 50 % each time.

-For the first installation, the interval among manufacture dates of battery modules shall not exceed 3 months.

-If a battery is replaced or added for capacity expansion, each battery's SOC should be consistent. The max. SOC difference should be between  $\pm 5\%$ .

-If users want to increase their battery system capacity, please ensure that the SOC of the existing system capacity is about 40%. The manufacture date of the new battery shall not exceed 6 months; in case of exceeding 6 months, please charge the new battery to around 40%.

## 10 Disclaimer

Triple Power protects this product under warranty when it is installed and used as listed in this manual. Violation of the installation procedure or use of the product in any way not described in this manual will immediately void all warranties on the product.

Triple Power does not provide warranty coverage or assume any liability for direct or indirect damages or defects that result from the following causes:

- Force majeure (flooding, lightning strike, overvoltage, fire, thunderstorm, flooding etc.)
- Improper or noncompliant use
- Improper installation, commissioning, start up or operation (contrary to the guidance detailed in the installation manual supplied with each product)
- Inadequate ventilation and circulation resulting in minimized cooling and natural air flow
- Installation in a corrosive environment
- Damage during transportation
- Unauthorized repair attempts
- Failure to adequately maintain the equipment. An on-site inspection by a qualified technician is possible following 120 months of continuous use. Warranty claims made beyond 120 months from date of commissioning may be declined if it cannot be demonstrated that the equipment has been adequately maintained
- External influence including unusual physical or electrical stress (power failure surges, inrush current, etc.)
- Use of an incompatible inverter or devices
- Connect to other brands inverters without authority from the company

# Warranty Registration Form



### For Customer (Compulsory)

Name ..... Country .....

Phone Number ..... Email .....

Address .....

State ..... Zip Code .....

Product Serial Number .....

Date of Commissioning .....

Installation Company Name .....

Installer Name ..... Electrician License No. ....

### For Installer

#### Module ( If Any )

Module Brand .....

Module Size(W) .....

Number of String ..... Number of Panel Per String .....

#### Battery ( If Any )

Battery Type .....

Brand .....

Number of Battery Attached .....

Date of Delivery ..... Signature .....

Please visit our warranty website: <https://www.solaxcloud.com/#/warranty> to complete the online warranty registration or use your mobile phone to scan the QR code to register.

For more detailed warranty terms, please visit SolaX official website: [www.solaxpower.com](http://www.solaxpower.com) to check it.





PLEASE REGISTER THE WARRANTY  
IMMEDIATELY AFTER INSTALLATION!  
GET YOUR WARRANTY CERTIFICATE  
FROM SOLAX!  
KEEP YOUR INVERTER ONLINE & WIN  
SOLAX POINTS!

1

Open your camera app and point your device at the QR code



2

Wait for the camera to recognize the QR code



3

Click banner or notification when it appears on the screen



4

Warranty registration page will be loaded automatically

